



## PM2

### Printing module 2"

PM2 is the **versatile and eco-friendly panel printer thanks to its energy efficient and paper saving** features, with high printing quality, which is used in several backgrounds and tools. Thanks to the possibility of printing on linerless paper and the **automotive ready** function, it is able to meet the market needs. PM2 is also fully compatible with the previous model (PLUS2) both for hardware and software.



## CHARACTERISTICS

### 1. New ergonomic design

with a simplified opening system

### 2. Paper saving functionality

to reduce paper use

### 3. Automotive ready

integrated anti-roll system

### 4. Linerless paper printing

and black mark label management

### 5. Extended range

8-42 V voltage

---

## APPLICATIONS

- Workshop equipment
  - Medical equipment
  - PC panel and control systems
  - Weighing instruments: industrial, portable
  - Fire detection systems
  - Sterilization equipment
  - Taximeters
  - Truck tachographs
  - Measurement devices
  - Cash handling system
- 

## ACCESSORIES

- Power supply
  - Starter Kit: power supply cable + serial/TTL interface 5 Volt
  - Extended range module from 8 Vdc to 42 Vdc
  - Gray frame 112x112 with clips
-

**TECHNICAL SHEET**

<b>Printing Method</b>	Thermal with fixed head
Resolution	203 dpi (8 dots/mm)
Printing speed	max 60mm/sec (@7.5V)
Supported Barcode	1D: UPC-A, UPC-E, EAN8, EAN13, CODE39, ITF, CODABAR, CODE93, CODE128, CODE32 2D: PDF417 and QRcode
Paper width	57 mm ± 0.5
Paper weight	from 55 to 70 g/m <sup>2</sup>
Paper thickness	from 63µm to 85µm
Roll Dimension	Ø 50mm
Printing width	48 mm
Printing mode	Normal, 90°, 180°, 270°
Printing format	Altezza/Larghezza da 1 a 8, grassetto, negativo, sottolineato, corsivo
Character set	European, International, Portuguese and Nordic, Chinese (GB18030), Katakana, Arabic, Greek, Turkish, Hebrew, and Cyrillic
Sensors	Head temperature, paper presence, black mark alignment
Emulation	CUSTOM/POS PLUS FH190
Interfaces	RS232/TTL, USB
Data Buffer	16Kb
Flash Memory	8MB (+768 Kb internal)
RAM Memory	256Kb internal
Graphic Memory	Logos dynamic management (max. 32 kB graphic memory)
Head life	100Km (100M pulses)
Drivers	Windows <sup>®</sup> (32/64 bit) – only on request WHQL and silent installation; CUPS Linux (32/64 bit); Virtual COM (Linux or Windows 32/64 bit); Android™
Software Tools	PrinterSet, CustomPowerTool, Custom Windows API
Power supply	from 4 Vdc to 8 Vdc (optional external power supply) from 8 Vdc to 42 Vdc with optional module for extended range (optional external power supply)
Typical	max. 3.2 A
Operating temperature	-20 a +70
Dimensions	With cover closed: 56.1 mm (L) x 85.5 mm (H) x 85 mm (W) With cover opened: 111.1 mm (L) x 85.5 mm (H) x 85 mm (W)
Weight	141 gr

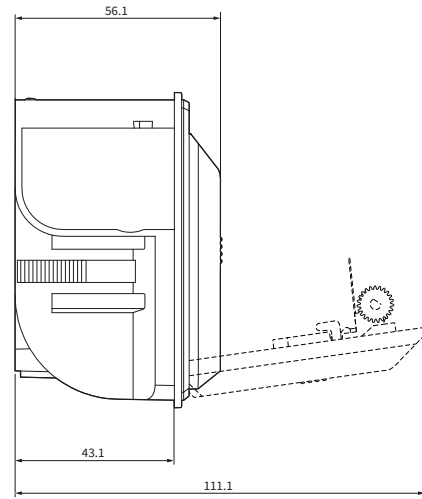
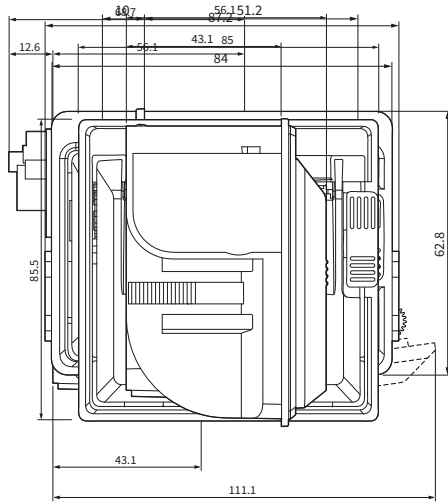

## MODELS



**915NB010100333**  
PRINTER PM2 USB RS232



**915NB030100333**  
PRINTING MECHANISM PM2 MEC

Via Berettine, 2 - 43010 Fontevivo PR - VAT: IT02498250345 - TEL: +39 0521 680111 - FAX: +39 0521 610701 - UNIQUE CODE: 8RQN7AZ

The technical data on this website are not binding and may be changed without advanced notice.

Last update: 24 June 2024