



Datasheet

IMPINJ R700 SERIES RAIN RFID READERS

DATASHEET

OVERVIEW

The Impinj R700 Series readers include the R700, R700 revision 2, and R720 RAIN RFID readers. These readers are designed to support enterprise RAIN deployments that need industry-leading performance, enterprise-grade reliability and security, and support for next-gen RAIN tags. IoT developers can easily build and deploy customized solutions with developer-friendly tools, increased processing power, and increased on-reader memory.

This document constitutes the electrical and mechanical specifications pertaining to the Impinj R700 Series RAIN RFID readers. It contains a functional overview, mechanical characteristics, and electrical specifications. For technical support, visit the Impinj Support Portal at support.impinj.com.

Table 1: Impinj R700 Series Key Specifications

SPECIFICATION	R700	R700 revision 2	R720
Physical Dimensions	With mounting brackets 8.4 in. long x 7.4 in. wide x 1.2 in. deep (21.5 cm x 18.7 cm x 3.0 cm) Without brackets: 8.4 in. width x 5.9 in. depth x 1.2 in. height inch (21.4 x 14.9 x 3.0 cm)		
Power Supply	PoE (802.3af), PoE+ (802.3at) with LLDP for power negotiation		
Air Interface Protocol	EPCglobal UHF Gen2 v2 / ISO 18000-63 RFID		
Antenna Ports	4, Monostatic (RP-TNC)		
Frequency Range	IPJ-R700-241 ETSI Reader 865 – 868 MHz, 915 – 921 MHz IPJ-R700-341 Global Reader: 902 – 928 MHz IPJ-R700-441 Japan Reader 916.7 to 920.9 MHz		IPJ-R720-243 ETSI Reader 865 – 868 MHz, 915 – 921 MHz IPJ-R720-343 Global Reader: 902 – 928 MHz IPJ-R720-443 Japan Reader: 916.7 to 920.9 MHz
Transmit Power	PoE+: 10 - 33 dBm max PoE: 10 - 30 dBm max	PoE+: 10 - 33 dBm max	PoE+: 10 - 33 dBm max PoE: 10 - 20 dBm max
Typical Receive Sensitivity	-93 dBm CISC 90% PSR		
Processor	Dual-Core 1 GHz Cortex A7	Dual-Core 1 GHz Cortex A53	Quad-Core 1.4 GHz ARM53
CAP Space	256 MB	768 MB	256 MB
Flash	1 GB		
RAM	1 GB, DDR3L 800 MHz	1 GB, LPDDR4 1.6 GHz	1 GB, DDR3L 800 MHz
Linux Operating System	5.10 kernel (32-bit)	6.6 kernel (64-bit)	5.10 kernel (32-bit)
Network Connectivity	10/100/1000 BASE-T Ethernet		
Device Connectivity	3 USB Type-A, 1 micro USB		
General Purpose I/O	2 in / 3 out		

Figure 1: Impinj R700 Series Top View



Figure 2: Impinj R700 Series Bottom View



Figure 3: Impinj R700 Series Front View



Figure 4: Impinj R700 Series Back View



Figure 5: Impinj R700 Series Left View



Figure 6: Impinj R700 Series Right View



TABLE OF CONTENTS

1	Introduction	1
1.1	Features	1
1.2	Block Diagram	1
2	Specifications	2
2.1	Mechanical	2
2.2	Environmental	2
2.3	RFID	3
2.3.1	Transmit Power	3
2.3.2	Gen2 and Gen2X™ Reader Modes	4
2.3.3	Read Rate	4
2.3.4	Receive Sensitivity	4
2.4	Connectivity	5
2.4.1	Power	5
2.4.2	GPIO	5
2.5	Operating System	7
3	Development Libraries	7
4	Regulatory Specifications	8
5	Ordering Information	9
5.1	Reader	9
5.2	Accessories and Warranties	9
5.3	Antennas and Antenna Cables	10
6	Impinj Fixed Reader Comparison	11
7	Additional User Documentation	12
8	Change Log	13
8.1	December 2025	Error! Bookmark not defined.
8.2	December 2023	Error! Bookmark not defined.
8.3	June 2020	13
8.4	October 2020	13
8.5	February 2021	13
8.6	November 2023	13
8.7	July 2025	13
8.8	December 2025	13
9	Notices	13

1 INTRODUCTION

The Impinj R700 Series are four-port RAIN RFID readers, compliant with the GS1 UHF Gen2v2 protocol which ISO/IEC standardizes as 18000-63. They also support Impinj Gen2X™, an enhancement to the RAIN standard that can improve inventory speed, increase read range, manage large tag populations, protect consumers, prevent label and item counterfeiting, and reduce overall solution cost. Impinj R700 Series are specifically designed to meet the increasing demands of next-generation IoT solutions and enterprise-grade RAIN deployments.

1.1 Features

- **Industry-leading sensitivity:** Empowers reading tags farther and faster, and future proofing of IoT solutions
- **Powerful edge processing:** Enables intelligent on-reader RAIN RFID tag-processing algorithms
- **Secure, upgradable Linux OS:** Delivers enterprise-grade security and reliability, and the flexibility to customize with on-reader applications
- **Simple IoT device interface:** Easily connects IoT applications to configure and control devices, and to consume RAIN data with native support for MQTT
- **Optimized design for inventory:** Increases read rate and improves read zone control at lower transmit power
- **Rich peripheral and accessory support:** Provides versatility with support for USB flash drives, Wi-Fi adapters, and up to 32 antennas via optional antenna hub

1.2 Block Diagram

Figure 7: Impinj R700 Series Block Diagram

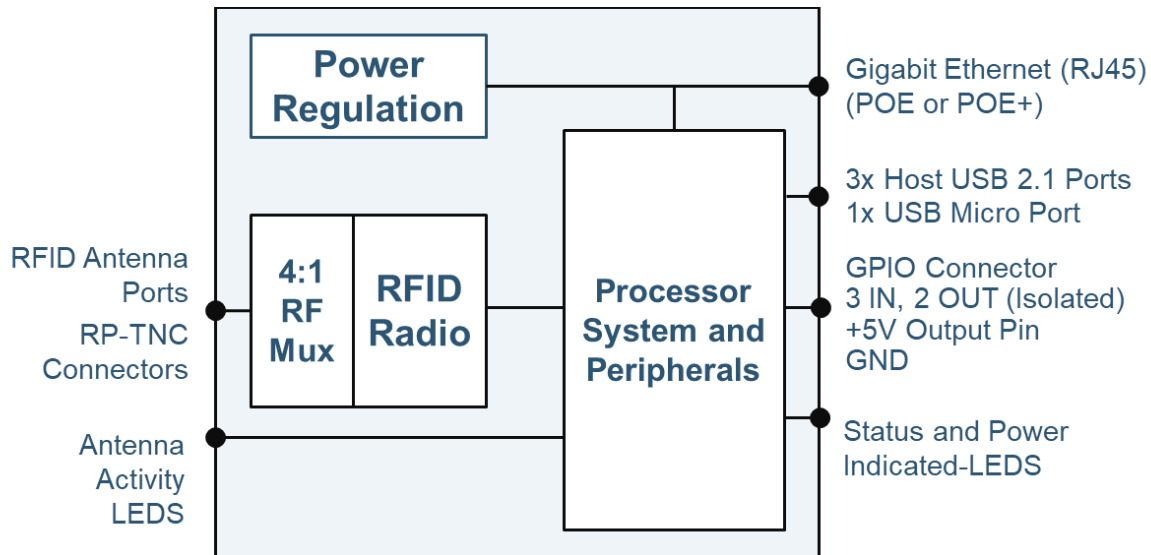

2 SPECIFICATIONS

2.1 Mechanical

Table 2: Impinj R700 Series Mechanical Specifications

SPECIFICATION	DESCRIPTION
Physical Dimensions	With mounting brackets 8.4 in. long x 7.4 in. wide x 1.2 in. deep (21.5 cm x 18.7 cm x 3.0 cm) Without brackets: 8.4 in. width x 5.9 in. depth x 1.2 in. height inch (21.4 x 14.9 x 3.0 cm)
Mounting	<ul style="list-style-type: none"> VESA 100 x100 mm on bottom of the enclosure Two removable brackets compatible with Impinj Speedway mounting system
Weight	2.12 lb., 0.96 kg
Housing Material	Die-cast Aluminum
Factory Reset Button	Restores reader to known factory state
LED Indicators	System status, inventory, firmware upgrade, antenna activity, network activity

2.2 Environmental

Table 3: Impinj R700 Series Environmental Specifications

SPECIFICATION	DESCRIPTION
Operating Temperature	-4° F to 122° F (-20° C to 50° C)
Storage Temperature	-4° F to 158° F (-20° C to 70° C)
Humidity	5% - 95% non-condensing
Sealing	Ingress Protection (IP) 50 rating
Shock and Vibration	MIL-STD-810G

2.3 RFID

Table 4: Impinj R700 Series RFID Specifications

SPECIFICATION	R700 / R700 revision 2	R720
Air Protocol	EPCglobal UHF Class 1 Gen 2 / ISO 18000-63 RFID Impinj Gen2X™ protocol and application layer enhancements	
Transmit Power	10 – 31.5 dBm (PoE+, ETSI Lower Band) 10 – 33 dBm (PoE+, FCC / ETSI Upper Band)	10 – 20 dBm (PoE, All Models) 10 – 31.5 dBm (PoE+, ETSI Lower Band) 10 – 33 dBm (PoE+, FCC / ETSI Upper Band)
Transmit Power Resolution	0.25 dB	
Transmit Power Accuracy	0.5 dB	
Frequency Range	IPJ-R700-341 Global Reader: 902 – 928 MHz IPJ-R700-241 ETSI Reader 865 – 868 MHz, 915 – 921 MHz IPJ-R700-441 Japan Reader 916.7 to 920.9 MHz	IPJ-R720-343 Global Reader: 902 – 928 MHz IPJ-R720-243 ETSI Reader 865 – 868 MHz, 915 – 921 MHz IPJ-R720-443 Japan Reader 916.7 to 920.9 MHz
Return Loss	10 dB min	
Read Rate	Up to 1100 reads per second	
Antenna Impedance	50 ohms	
Receive Sensitivity*	Ideal: -94 dBm Typical: -93 dBm Challenging: -88 dBm	
Gen 2 Reader Modes	Static and Dynamic RF Modes various per region	

*Data collected using CISC conducted sensitivity test, 90% PSR. Using RF mode FCC DRM M8 @ 30 dBm. Conditions described in Table 5:

2.3.1 Transmit Power

The user configures Impinj R700 Series transmit power, the conducted power available at the RF port on the reader.

2.3.1.1 R700

For Impinj R700 reader model, the reader will limit the maximum transmit power to 30 dBm while configured to use PoE power. When configured to use PoE+ power, the reader may allow for a higher maximum transmit if the region allows for it. The Impinj R700 will only present valid output powers for the region it is configured to operate in. For additional information on how to properly set transmit power to comply with regulatory rules, refer to the Impinj R700 Series Installation and Operations Guide. For additional information on the differences between PoE and PoE+ power, refer to section 2.4.1 of this datasheet.

2.3.1.2 R700 revision 2

The Impinj R700 revision 2 reader model requires PoE+ power for all operations and all transmit power levels, from 10 dBm to a maximum of 33 dBm, depending on regional regulations. Selecting the correct region of operation will limit the transmit power options available to only those within the region's limit. For additional information on how to properly set transmit power to comply with regulatory rules, refer to the Impinj R700 Series Installation and Operations Guide. For additional information on the differences between PoE and PoE+ power, refer to section 2.4.1 of this datasheet.

2.3.1.3 R720

For all Impinj R720 reader model, the reader will limit the maximum transmit power to 20 dBm while configured to use PoE power. When configured to use PoE+, the reader can transmit the full allowable transmit power range based on region. The Impinj R720 will only present valid output powers for the region it is configured to operate in. For additional information on how to properly set transmit power to comply with regulatory rules, refer to the Impinj R700 Series Installation and Operations Guide. For additional information on the differences between PoE and PoE+ power refer to section 2.4.1 of this datasheet.

2.3.2 Gen2 and Gen2X™ Reader Modes

The Impinj R700 Series readers include support for two types of reader modes: static and dynamic. The number of modes varies per region and comply with regulatory agencies. All R700 Series readers have Gen2X reader modes available (identified as 5XXX in the reader mode listing). These reader modes seamlessly operate between Gen2 and Gen2X™ inventories for improved reader sensitivity and inventory speeds on Gen2X™ enabled tags. For additional information on Reader Modes visit the Impinj Support Portal.

2.3.3 Read Rate

The Impinj R700 Series reader's read rate varies depending on the reader configuration and number of tags in the field of view. The maximum read rate can only be achieved while using reader mode 0 in an FCC-like region.

2.3.4 Receive Sensitivity

Impinj follows the RAIN Alliance and ISO/IEC 18046-2:2020 recommended receive sensitivity methodology. This methodology uses the CISC Xplorer and its tag emulator for conducted receive sensitivity testing. The benchmark used is based on a Packet Success Rate (PSR) of 90%. Impinj has created three conditions using this methodology to showcase a gradation of performance based on adjacent equipment selection. The conditions are described in Table 5.

Table 5: Impinj R700 Series Receive Sensitivity Conditions

CONDITION	TIME DELAY (ns)	RETURN LOSS (dB)
Ideal	4.5	22+
Typical	6.0	15
Challenging	38.2	12

The receive sensitivity of the Impinj R700 Series readers varies depending on the reader mode chosen to perform inventory. Applications that require the lowest (i.e., best) receive sensitivity should choose Dense Reader M8 mode. To learn more about reader modes and receive sensitivity, visit the [Impinj Support Portal](#).

2.4 Connectivity

Table 6: Impinj R700 Series Connectivity Specifications

SPECIFICATION	R700 / R720	R700 revision 2
Network	10/100/1000 Base-T Ethernet (RJ45)	
Antenna Ports	4 monostatic ports (RP-TNC)	
USB	3 Type A host, 1 micro device	
Power	PoE (802.3af), PoE+ (802.3at) with LLDP for power negotiation	PoE+ (802.3at)
General Purpose I/O	2 in, 3 out optically isolated	
General Purpose I/O Header	Phoenix Contact 9 pin 3.81 mm pitch	

2.4.1 Power

The Impinj R700 and R720 readers are powered exclusively through Power over Ethernet (PoE) or PoE+ via the ethernet port. Impinj R700 is limited to 30 dBm transmit power in PoE and R720 is limited to 20 dBm transmit power in PoE. For applications where the reader is not connected to a PoE capable switch, users can apply a midspan injector to add inline power to a network connection via a power supply. By default, the Impinj R700 and R720 will attempt to negotiate power using Link Layer Discovery Protocol (LLDP). If the negotiation fails, the Impinj R700 and R720 will default to using PoE power.

The Impinj R700 revision 2 readers are powered exclusively through PoE+ via the ethernet port. For applications where the reader is not connected to a PoE+ capable switch, users can apply a midspan injector to add inline power to a network connection via a power supply.

Impinj recommends PoE+ power when using the Impinj R700 Series readers to source power to external USB devices or through the general-purpose outputs.

2.4.2 GPIO

The Impinj R700 Series readers utilizes a Phoenix Contact 9 position 3.81 mm pitch header to expose the GPIO signals. To connect external signals, a matching terminal block must be installed. Pin 1 is located nearest the push-pin factory reset button.

Table 7: Impinj R700 Series GPIO Pin Assignments

PIN	ASSIGNMENT
1	+5V (500 mA max current)
2	Chassis GND
3	IN 0
4	IN 1
5	OUT 0
6	OUT 1
7	OUT 2
8	V MINUS
9	V PLUS

Figure 8: Impinj R700 Series GPIO Pin Locations



Table 8: Impinj R700 Series GPIO Electrical Specifications

SPECIFICATION	DESCRIPTION
V PLUS	5 – 30 V (reference to V MINUS)
Input Logic 0	0 - 0.8 V
Input Logic 1	3 – 30 V
Output Logic 0	0 – 0.5 V (reference to V MINUS)
Output Logic 1	V PLUS – 0.5 V
GPO Current Draw	1.5 A Source or Sink
Isolation	Optical

2.5 Operating System

Table 9: Impinj R700 Series Operating System Specifications

SPECIFICATION	R700	R700 revision 2	R720
Processor	Dual-Core 1 GHz Cortex A7	Dual-Core 1 GHz Cortex A53	Quad-core 1.4 GHz ARM53
CAP Space	256 MB	768 MB	256 MB
Flash	1 GB		
RAM	1 GB, DDR3L 800 MHz	1 GB, LPDDR4 1.6 GHz	1 GB, DDR3L 800 MHz
Linux Operating System	5.10 kernel (32-bit)	6.6 kernel (64-bit)	5.10 kernel (32-bit)
Firmware	Impinj Octane Firmware		
Firmware Upgrade	Web-based and remote capable		
Network Stack	IPv4, IPv6		
Network Services	SSH, HTTP, HTTPS, NTP, DHCP, SFTP, mDNS		
Network Security	802.1x port security		
Network Management	Event logs with syslog forwarding		

3 DEVELOPMENT LIBRARIES

Table 10: Impinj R700 Series Supported Development Libraries

API	DESCRIPTION
Reader configuration REST API	OpenAPI compatible RESTful configuration API with support for over 80 languages.
Impinj Octane SDK	Host-based applications (.NET, Java)
Impinj Octane LLRP toolkit	Host-based applications (.NET, Java, C, C++) compatible with LLRP 1.0.1 with Impinj Extensions
Impinj R700 embedded toolkit	Compiler (C, C++) and precompiled Octane LLRP libraries to develop on-reader applications

4 REGULATORY SPECIFICATIONS

Table 11: Impinj R700 Series Regulatory Specifications

SPECIFICATION	R700 / R700 revision 2	R720
RF	USA and Canada <ul style="list-style-type: none"> Federal Communications Commission (FCC) Part 15.247 and 15.249 Professional Installation required under FCC rules ETSI <ul style="list-style-type: none"> EN 302 208 v3.3.0 EN 301 489-3 v2.2.1 EN 300 489-1 v2.2.0 Japan <ul style="list-style-type: none"> ARIB STD-T106 	USA and Canada <ul style="list-style-type: none"> Federal Communications Commission (FCC) Part 15.247 and 15.249 Professional Installation required under FCC rules ETSI <ul style="list-style-type: none"> EN 302 208 v3.3.0 EN 301 489-3 v2.2.1 EN 300 489-1 v2.2.0 Japan <ul style="list-style-type: none"> ARIB STD-T106
Safety	USA and Canada <ul style="list-style-type: none"> UL listed EU <ul style="list-style-type: none"> CE mark 	
Hazardous Substances	RoHS3 2015/863 compliant	

The latest regional certifications are available on the Impinj Support Portal.

5 ORDERING INFORMATION

5.1 Reader

Table 12: Impinj R700 Part Number Information

ORDERING PART NUMBER	DESCRIPTION
IPJ-R700-241	Impinj R700 RAIN RFID reader, 4-Port, ETSI
IPJ-R700-341	Impinj R700 RAIN RFID reader, 4-Port, FGX
IPJ-R700-441	Impinj R700 RAIN RFID reader, 4-Port, Japan

Table 13: Impinj R700 revision 2 Part Number Information

ORDERING PART NUMBER	DESCRIPTION
IPJ-R700-241-B	Impinj R700 RAIN RFID reader, 4-Port, ETSI, revision 2
IPJ-R700-341-B	Impinj R700 RAIN RFID reader, 4-Port, FGX, revision 2
IPJ-R700-441-B	Impinj R700 RAIN RFID reader, 4-Port, Japan, revision 2

Table 14: Impinj R720 Part Number Information

ORDERING PART NUMBER	DESCRIPTION
IPJ-R720-243	Impinj R720 RAIN RFID reader, 4-Port, ETSI
IPJ-R720-343	Impinj R720 RAIN RFID reader, 4-Port, FGX
IPJ-R720-443	Impinj R720 RAIN RFID reader, 4-Port, Japan

5.2 Accessories and Warranties

Table 15: Impinj R700 Series Hardware Accessories and Services

PART NUMBER	NAME	DESCRIPTION												
IPJ-A6010	ImpinjR700 antenna hub	The Impinj R700 antenna hub expands the number of antennas that can connect to an Impinj R700 reader by allowing eight antennas to connect to one antenna port for a total of 32 antennas per reader. The R700 antenna hub is compatible with all R700 Series Readers.												
IPJ-A2010	PoE+ Midspan Injector	PoE+ midspan power injector (without AC power cord)												
IPJ-A2041-xxx	AC Power Cord for PoE+ injector	<table border="0"> <tr> <td>ARG</td> <td>Argentina</td> <td>RSA</td> <td>South Africa</td> </tr> <tr> <td>AUS</td> <td>Australia, New Zealand</td> <td>UK1</td> <td>UK, Singapore</td> </tr> <tr> <td>BRA</td> <td>Brazil</td> <td></td> <td>Malaysia, Hong Kong</td> </tr> </table>	ARG	Argentina	RSA	South Africa	AUS	Australia, New Zealand	UK1	UK, Singapore	BRA	Brazil		Malaysia, Hong Kong
ARG	Argentina	RSA	South Africa											
AUS	Australia, New Zealand	UK1	UK, Singapore											
BRA	Brazil		Malaysia, Hong Kong											

		CHN China	USA USA
		EU1 Europe	
		IND India	
		JPN Japan	
IPJ-C205x	Warranty extension	1 1-year	
		2 2-year	
		3 3-year	
IPJ-C2001	Firmware Updates	Firmware Updates (1-year)	

5.3 Antennas and Antenna Cables

Table 16: Antenna and Antenna Cable Ordering Information

PART NUMBER	PART NAME	DESCRIPTION
IPJ-A0303-000	Impinj Mini-Guardrail Antenna	Impinj Mini-Guardrail antennas are ideal for fixed spaces that need exceptional control in a small zone. The antenna is unobtrusive and optimal for monitoring items within cabinets or other small enclosures. Provides broadband support for optimal performance globally.
IPJ-A0404-000	Impinj Matchbox Antenna	The Impinj MatchBox antenna is ideal for tight-proximity spaces that need exceptional control in a small zone. The antenna is unobtrusive and can monitor items within cabinets or other small enclosures. Provides bi-directional, short-range coverage and broadband support for optimal performance globally.
IPJ-A300x-000	Antenna Cable 2 2 meters 4 4 meters 8 8 meters	RG58, SMA male to R-TNC male
IPJ-A311x-000	Antenna Cable 2 2.1 meters 4 4.6 meters	Low Loss/High Flex, SMA male to R-TNC male
IPJ-A312x-000	Antenna Cable 2 2.1 meters 4 4.6 meters	Low Loss/High Flex, SMA male to SMA male

6 IMPINJ FIXED READER COMPARISON

Table 17: Impinj Fixed Reader Comparison

FEATURE	R700	R700 revision 2	R720	R420	R220
Antenna Ports	4	4	4	4	2
Read Zones (max)	32	32	32	32	16
Read Rate (max per-second)	1100	1100	1100	1100	200
Transmit Power (max, dBm)	33.0	33.0	33.0	32.5	32.5
Receive Sensitivity* (Typical, dBm)	-93	-93	-93	-84	-84
Processor Speed	1 GHz (dual core)	1 GHz (dual core)	1.4 GHz (quad core)	400 MHz (single core)	400 MHz (single core)
Random Access Memory (MB)	1024	1024	1024	256	256
Custom Application Partition (MB)	256	768	256	32	32
Impinj IoT device interface	Yes	Yes	Yes	No	No
USB Peripheral Slots	3	3	3	1	1
GPIO Connector	Integrated	Integrated	Integrated	Accessory	Accessory
Ethernet Network Speed	10/100/1000	10/100/1000	10/100/1000	10/100	10/100
Power Over Ethernet Support	PoE PoE+	PoE+	PoE+ (PoE - Reduced Tx Power)	PoE PoE+ EU2 model	PoE

*Data collected using CISC conducted sensitivity test, 90% PSR. Using RF mode FCC DRM M8 @ 30 dBm. Ideal condition; 6.0ns time delay and 15dB return loss

7 ADDITIONAL USER DOCUMENTATION

The following table lists documents that may be helpful in operating the Impinj R700 Series Readers. These documents can be found on the Impinj Support Portal at [Impinj R700 Reader Documents](#).

Table 18: Impinj R700 Series User Documentation

DOCUMENT	DESCRIPTION
Impinj R700 Series Quick Start Guide	Simple guide to begin using Impinj R700 Series readers
Impinj R700 Series Installation and Operations Guide	Detailed instructions for installing, connecting, configuring, operating, upgrading, and troubleshooting the Impinj R700 Series Readers
RShell Reference Manual	Guide to using the Reader Shell (RShell) command line interface to configure, maintain, and query the status of Impinj RAIN RFID readers
Impinj Octane LLRP Guide	Describes the LLRP capabilities supported by Impinj RAIN RFID readers, which includes Impinj custom LLRP extensions
Impinj R700 Series Embedded Development Quick Start Guide	Guide to begin developing custom on-reader applications
Impinj R700 Series Firmware Release Notes	Details up to date features and known issues

8 CHANGE LOG

8.1 June 2020

- Updated to include Impinj R700 ETSI reader model information
- Updated to reflect features of Impinj R700 firmware version 7.1
- Minor formatting changes

8.2 October 2020

- Updated to include Impinj R700 FGX reader model information
- Removed Impinj R700 FCC reader model information
- Updated to reflect features of Impinj R700 firmware version 7.3
- Minor formatting changes

8.3 February 2021

- Updated to include Impinj R700 Japan reader model information
- Updated Accessory table to include Impinj R700 antenna hub and Impinj R700 water-resistant case
- Updated to reflect features of Impinj R700 firmware version 7.4
- Updated specification table to indicate Impinj Speedway R120 End-of-Life status
- Minor formatting changes

8.4 November 2023

- Updated to include R720 reader model information
- Updated receive sensitivity values to reflect new methodology
- Removed R120 reader model information
- Removed end-of-life accessories
- Minor formatting changes

8.5 July 2025

- Updated Accessory table to remove Impinj R700 water-resistant case as this product has reached End-of-Life status.

8.6 December 2025

- Update included Impinj R700 revision 2 reader model information.

9 NOTICES

Copyright All rights reserved.

Impinj gives no representation or warranty, express or implied, for accuracy or reliability of information in this document. Impinj reserves the right to change its products and services and this information at any time without notice.

EXCEPT AS PROVIDED IN IMPINJ'S TERMS AND CONDITIONS OF SALE (OR AS OTHERWISE AGREED IN A VALID WRITTEN INDIVIDUAL AGREEMENT WITH IMPINJ), IMPINJ ASSUMES NO LIABILITY WHATSOEVER AND IMPINJ DISCLAIMS ANY EXPRESS OR IMPLIED WARRANTY, RELATED TO SALE AND/OR USE OF IMPINJ PRODUCTS INCLUDING LIABILITY OR WARRANTIES RELATING TO FITNESS FOR A PARTICULAR PURPOSE, MERCHANTABILITY, OR INFRINGEMENT.

NO LICENSE, EXPRESS OR IMPLIED, BY ESTOPPEL OR OTHERWISE, TO ANY PATENT, COPYRIGHT, MASKWORK RIGHT, OR OTHER INTELLECTUAL PROPERTY RIGHT IS GRANTED BY THIS DOCUMENT.

Impinj assumes no liability for applications assistance or customer product design. Customers should provide adequate design and operating safeguards to minimize risks.

Impinj products are not designed, warranted or authorized for use in any product or application where a malfunction may reasonably be expected to cause personal injury or death, or property or environmental damage ("hazardous uses"), including but not limited to military applications; life-support systems; aircraft control, navigation or communication; air-traffic management; or in the design, construction, operation, or maintenance of a nuclear facility. Customers must indemnify Impinj against any damages arising out of the use of Impinj products in any hazardous uses

Statements concerning Impinj product performance are based on Impinj's internal modeling and test data, actual results may vary.

Impinj, and Impinj products and features are trademarks or registered trademarks of Impinj, Inc. For a complete list of Impinj Trademarks, visit www.impinj.com/trademarks. All other product or service names may be trademarks of their respective companies.

The products referenced in this document may be covered by one or more U.S. patents. See www.impinj.com/patents for details.